

ZONE	REV.	DESCRIPTION	DATE	APPROVED
		ENGINEERING APPROVAL	08.03.30	

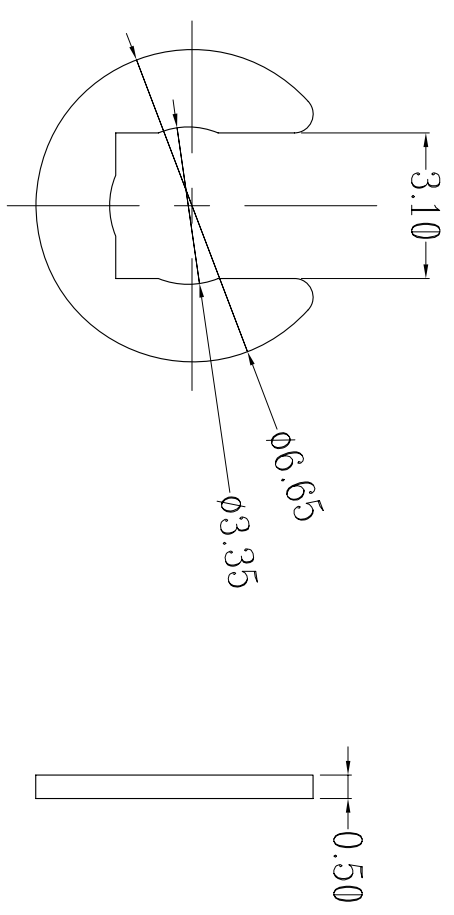

THIRD ANGLE PROJECTION

DRAWN		TITLE:		ST-	
CHECKED		PART NO:			
APPROVED		DWG NO:			
MATE	SCALE	1:1	REV	A	SHEET

A B C D E F G  
1 2 3 4 5