



NEX1 Technologies Co., Ltd

Mechanical Test Report of Mini-Armored Optical Fiber Cable

Product : AC -1 -S1 -30 -PV -B -0001

Written Date: 2005.3.6

Version: 1st edition

Approved by	Checked by	Written by

Revised Record	Revised Date	Written by	Approved by
2 nd edition			
3 rd edition			
4 th edition			
5 th edition			



NEX1 Technologies Co., Ltd

Contents

Chapter 1	
Introduction.....	3
Chapter 2 Test	
Scope.....	4
Chapter 3 Test Condition and	
Results	9
Chapter 4	
Conclusion.....	21
Chapter 5	
References.....	22



NEX1 Technologies Co., Ltd

Chapter 1 Introduction

NEX1's "Mini-Armored Optical Fiber Cable" is to make the optical fibers protected by the micro-diameter stainless metal with jacket and can be electric cable-like handling and easy to installation. This latest armored optical cable is different from the traditionalistic product for the characteristics that it has developed with a micro diameter armored flexible tube in stainless steel in order to prevent optical fiber from easy-destroyed and broken and it can be covered with flame-resistance jacket. In order to ensure the firmly conjunction, we also offer relative strong type connector. This unique design can make the construction process more convenient, reduce the loss and extend the fiber's life.

To demonstrate the reliability of NEX1's "Mini-Armored Optical Fiber Cable" to customers. NEX1 performed its mechanical testing according to the international standards-IEC 60794-1-2, TIA/EIA -455, and another standard such as Telcordia documents, like "GR-409-Core" was also referred to.

This report summarizes the test results and all test conditions, including the equipments and methods, are also described in detailed.

Chapter 2 Test Scope

In this chapter , we describe the specification of samples ,test equipments and all test items briefly.

2-1 Specification of samples.

The specification of Kaiphone’s mini -armored optical fiber cable described in the table 2-1.

Table 2-1 Specification of mini- armored optical fiber cable

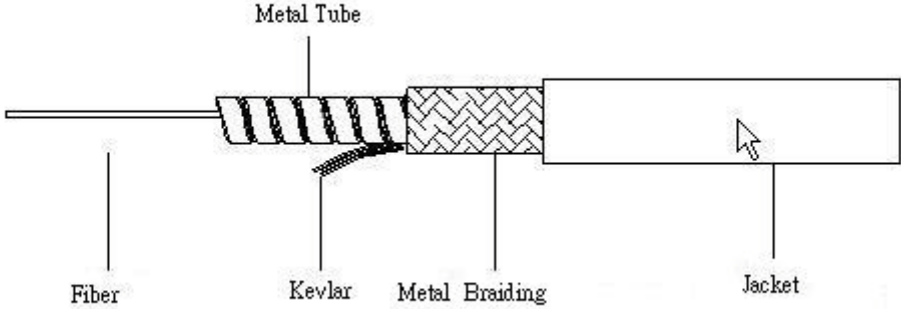
Type: Mini-armored optical fiber cable		Structure	
			
Cable	Armored Flexible Tube	Fiber Type	SM or MM 0.6mm PVC Fiber
		Number of Optical Fibers	1
		Tube Material	Stainless
		Inner Diameter of Metal Tube	1.1mm±0.05mm
		Outer Diameter of Metal Tube	1.6mm±0.05mm
		Weight	16±1Kg/Km
		Tensile Strength	200N
		Anti-tensile member	Kevlar
		Metal Braiding	0.07mm stainless wire
	Minimum Bending Radius *1	30mm	
Jacket	Pressure Resistance	300kgf/100mm	
	Material	Flame-resistance PVC or PE	
	Outer Diameter	3.0mm±0.2mm	
Temperature Range		-20℃ ~85℃	
Note: *1. It means the bending radius of armored flexible metal tube .			



NEX1 Technologies Co., Ltd

2-2 Test Item

The mechanical tests of NEX1's mini -armored optical fiber cable are according to IEC 60794-1-2 and TIA/EIA 455 standards, the details are described as following.

Table2-2 Mechanical Test

Category	Test Item	Test Method	Pass/Fail Criteria
Mechanical Test	Tensile test	IEC 60794-1-2-E1 / TIA/EIA-455-33	Δ I.L.<0.2db
	Crush	IEC 60794-1-2-E3 / TIA/EIA-455-41	Δ I.L.<0.2db.
	Impact	IEC 60794-1-2-E4 / TIA/EIA-455-25	Δ I.L.<0.2db
	Repeated Bending	IEC 60794-1-2-E6 / TIA/EIA-455-104	Δ I.L.<0.2db
	Torsion	IEC 60794-1-2-E7 / TIA/EIA-455-85	Δ I.L.<0.2db
	Bend	IEC 60794-1-2-E11 / TIA/EIA-455-37	Δ I.L.<0.2db

2-3 Test Instruments

The test instruments used in this report including :

- (1) Computer control materials testing system



Fig.2-1 Computer control materials testing system

(2) Optical power and back-reflection meter.



Fig.2-2 JDSU Optical power and back-reflection meter

(3) Impact tester



Fig.2-3 Impact tester

(4) Bending tester



Fig.2-4 Bending tester

(5)Torsion tester



Fig.2-5 Torsion tester

The optical characteristics of all samples under test were measured using JDSU optical power and back-reflection meter (Made in Canada).The tensile and crush test of mini-armored optical cables are using computer control materials testing system HT-9112 (Made in Taiwan).The other testing instruments including impact, bending and torsion tests are made by NEX1 as shown in the figure 2-3 to2-5.

Chapter 3 Test Condition and Results

The tests description and results are presented in this chapter

3-1 Tensile Test

a. Purpose

In order to examine the mini- armored optical fiber cable 's behavior of attenuation and /or the fiber elongation as a function of the load on this cable which may occurred during installation., we measure it's tensile strength according to the IEC 60794-1-2-E1 and TIA/EIA-455-33

b. Apparatus

- (1) Computer control materials testing system-HT-9112
- (2) Optical power and back-reflection meter-JDSU RM3750

c. Testing Method

As IEC-60794-1-2-E1 /TIA/EIA-455-33 testing setup, Fig. 3-1, mount the cable,50cm of length, onto the testing rig and secure it. Connect the test fiber of the cable to the measurement apparatus. then applying the load to the cable and record the attenuation of fibers.



NEX1 Technologies Co., Ltd

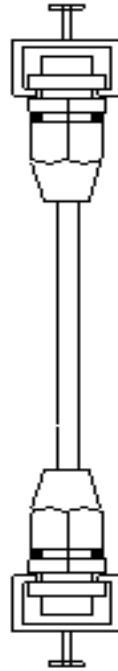

Fig.3-1 Schematic diagram of tensile test setup

d. Test conditions and results

Standard No.: IEC 60794-1-2-E1/ TIA/EIA-455-33

Cable Length for testing: 0.5 m

Tensile Used: 50 Kilogram Force

Duration: 10 minute

Criteria: Attenuation increase less than 0.2 dB

Results:

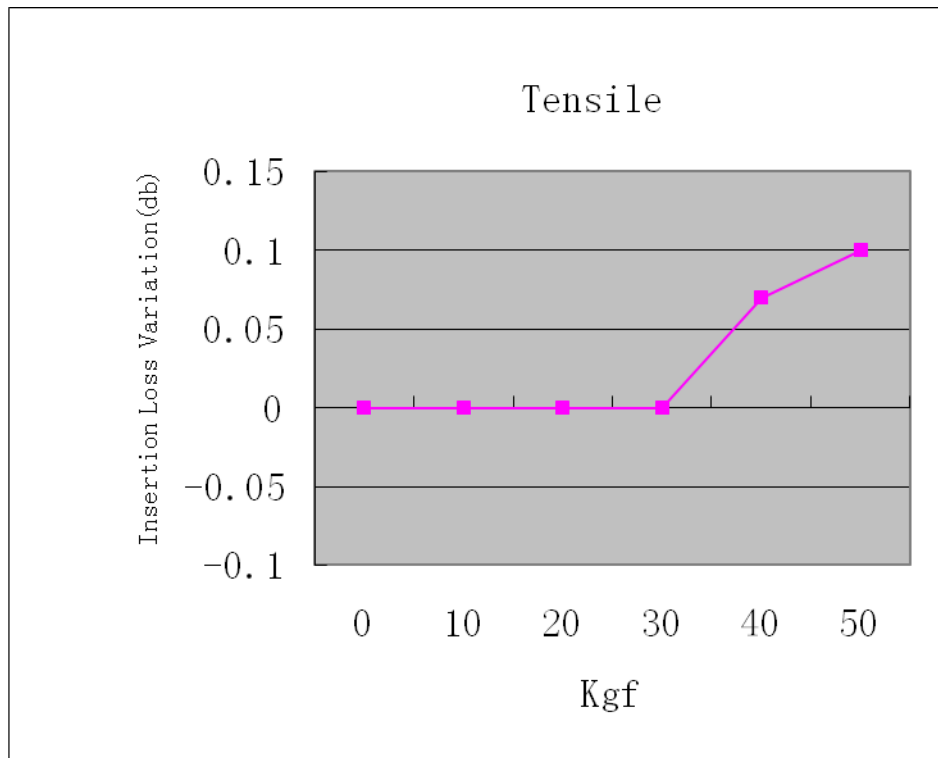

Fig.3-2 The average insertion loss variation of cable tensile test

3-2 Crush Test

a. Purpose

The purpose of this test is to determine the ability of NEX1's mini-armored optical fiber cable to withstand crushing. we measure it's anti-crushing strength according to the IEC 60794-1-2-E3 and TIA/EIA-455-41 standard.

b. Apparatus

- (1) Computer control materials testing system-HT-9112
- (2) Optical power and back-reflection meter-JDSU RM3750

c. Testing Method

As IEC-60794-1-2-E3 /TIA/EIA-455-41 testing setup, Fig. 3-3, put the cable between a flat steel base plate and a movable steel plate which applies a crushing force uniformly over a 100mm length of the sample for 10 min., The attenuation increase is less than 0.2dB after the load is released.

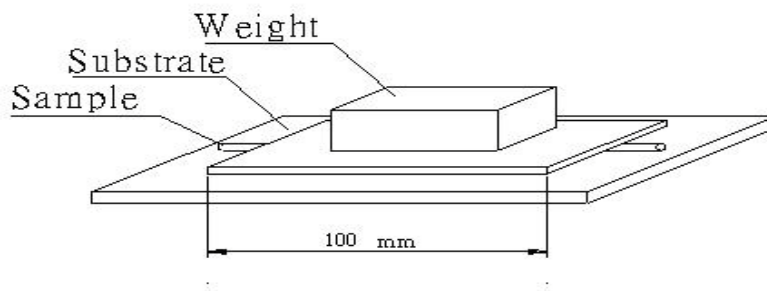

Fig.3-3 Crush Test

d. Test conditions and results

Standard No.: IEC 60794-1-2-E3 /TIA/EIA-455-41

Cable Length for testing: 100 mm

Crush Force: 300 kilogram force

Duration: 10 minutes

Criteria: Attenuation increase less than 0.2 dB after the load is released.



NEX1 Technologies Co., Ltd

Results:

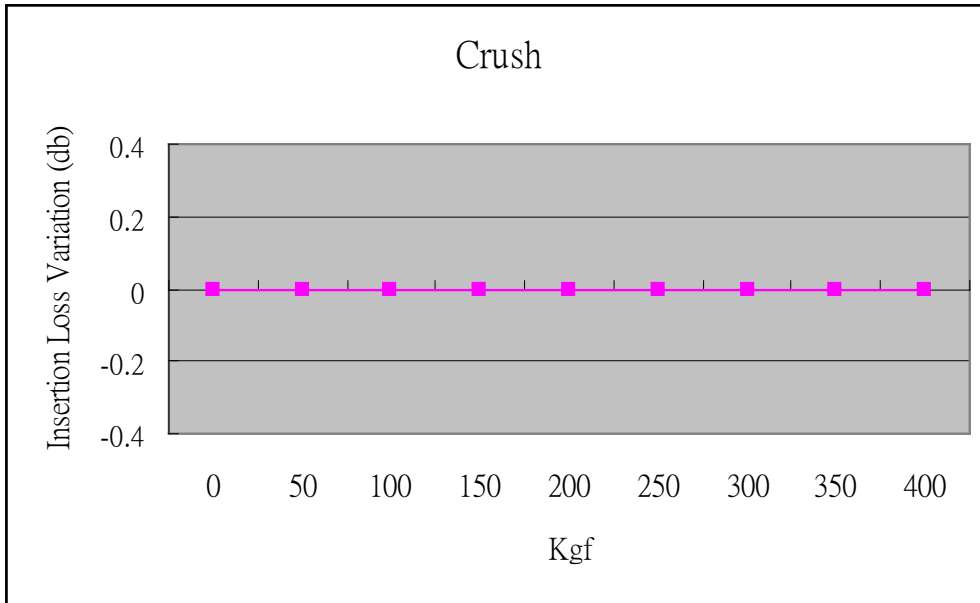

Fig.3-4 The average insertion loss variation of cable crush test



NEX1 Technologies Co., Ltd

3-3 Impact Test

a. Purpose

The purpose of this test is to determine the ability of NEX1's mini-armored optical fiber cable to withstand impact. we measure it's ant-impact strength according to the IEC 60794-1-2-E4 and TIA/EIA-455-25.

b. Apparatus

- (1) Impact tester.
- (2) Optical power and back-reflection meter-JDSU RM3750.

c. Testing Method

As IEC-60794-1-2-E4 /TIA/EIA-455-25 testing setup, Fig. 3-5, the cable is horizontally lay on a plate, a drop hammer continuously strike the cable for 150 times with a impacting frequency 30 times per minute,. The weight of hammer and the impacting energy depend on the cable diameter. The impacting energy is the potential energy of the hammer of 150 ± 5 mm height from the sample surface. The attenuation increase should less than 0.2 dB after testing.

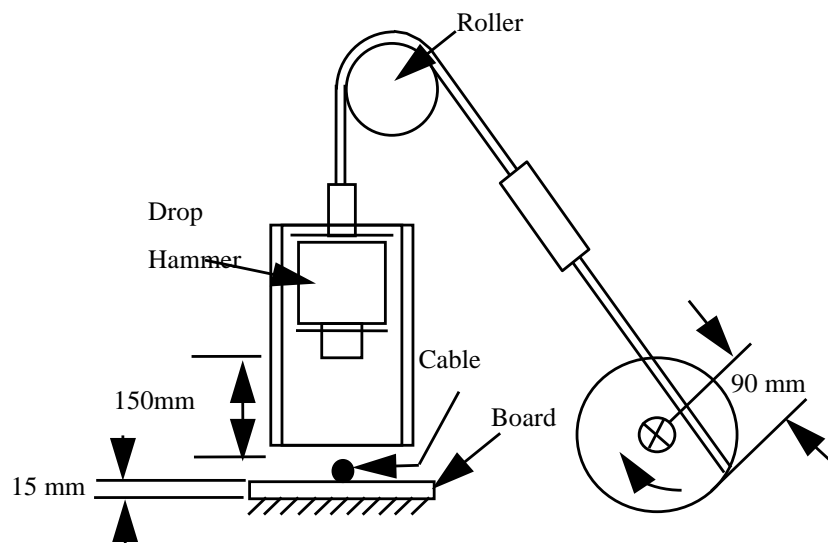

Fig.3-5 Impact tester

d. Test conditions and results

Standard No.: IEC 60794-1-2-E4/TIA/EIA-455-25

Cable Length for testing: one cable drum

Weight: 2Kg (Depend on cable diameter)

Frequency used: 30 times per minute

Duration: 5 minutes

Hammer Height: at 150 + 5 mm height

Criteria: Attenuation increase less than 0.2 dB

Results:

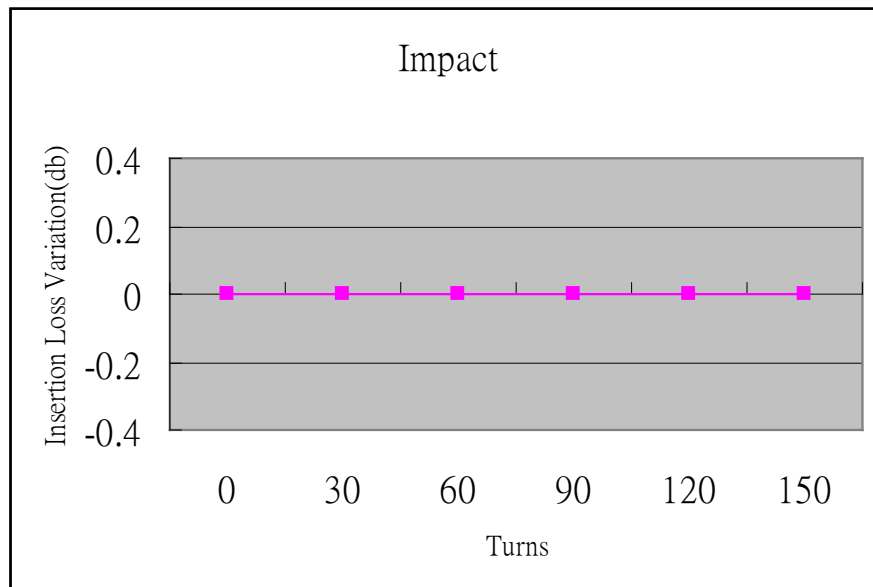

Fig.3-6 The average insertion loss variation of cable impact test

3-4 Repeated Bending Test

a. Purpose

The purpose of this test is to determine the ability of NEX1's mini-armored optical fiber cable to withstand repeated bending. we measure it's loss variation according to the IEC 60794-1-2-E6 and TIA/EIA-455-104

b. Apparatus

- (1) Bending tester
- (2) Optical power and back-reflection meter-JDSU RM3750

c. Testing Method

As IEC-60794-1-2-E6/ TIA/EIA-455-104 testing setup, Fig. 3-7, the cable is fixed in a close helix manner with a weight loaded on it (the load will depend on the cable diameter), and the bending diameter is 20 times of cable diameter. The cable is bent forwards and backwards through 180° for 25 times with a bending frequency is 30 times per min. The attenuation increase should be less than 0.2dB.



NEX1 Technologies Co., Ltd

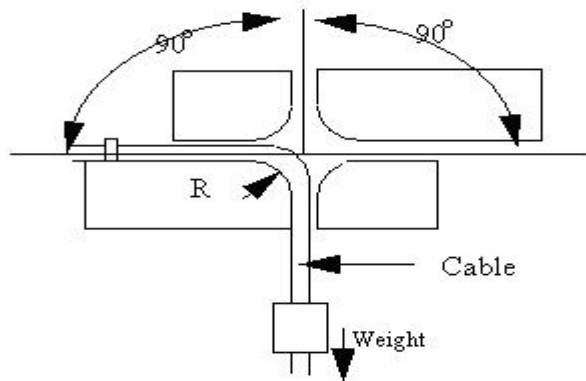

Fig.3-7 Bending tester

d. Test conditions and results

Standard No.: IEC 794-1-2-E6 /TIA/EIA-455-104

Cable Length for testing: 1 m

Weight: 2Kg

Bending diameter: 20 times of cable diameter

Duration: 25 times within 30 minutes

Criteria: Attenuation increase less than 0.2 dB

Results:

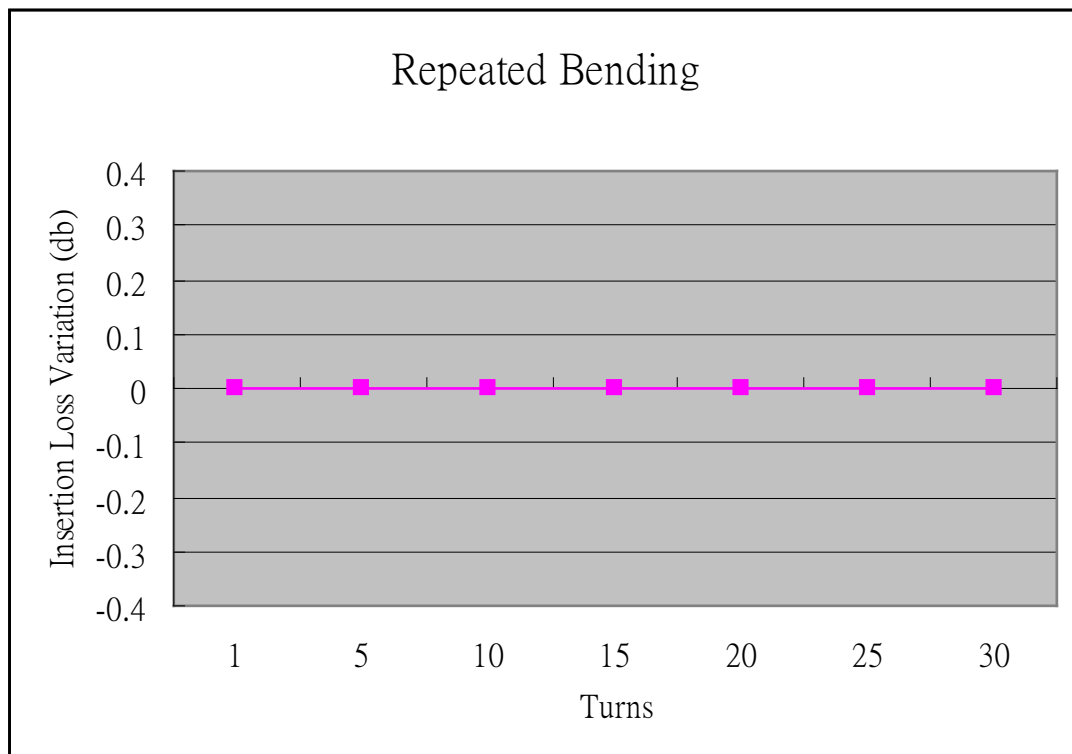

Fig.3-8 The average insertion loss variation of cable repeated bending test

3-5 TorsionTest

a. Purpose

The purpose of this test is to measure any variation in the optical power transmittance of a fiber when this mini-armored optical fiber cable is subjected to torsion force external to the cable jacket. we measure it's loss variation according to the IEC 60794-1-2-E7 and TIA/EIA-455-85.

b. Apparatus

- (1) Torsion tester
- (2) Optical power and back-reflection meter-JDSU RM3750

c. Testing Method

As IEC-794-1-2-E7/ EIA/TIA-FOTP-455-85 testing setup, Fig. 3-9, mount the cable to the two clamps, which are 4 meters from each other, of the testing apparatus. One clamp is fixed, the other is rotating. Rotating the cable with a frequency 1 cycle per minute ($\pm 180^\circ$ is a cycle), for a total is 10 cycles, Rest the cable for at least 5 minutes, as. The attenuation increase is less than 0.2 dB.

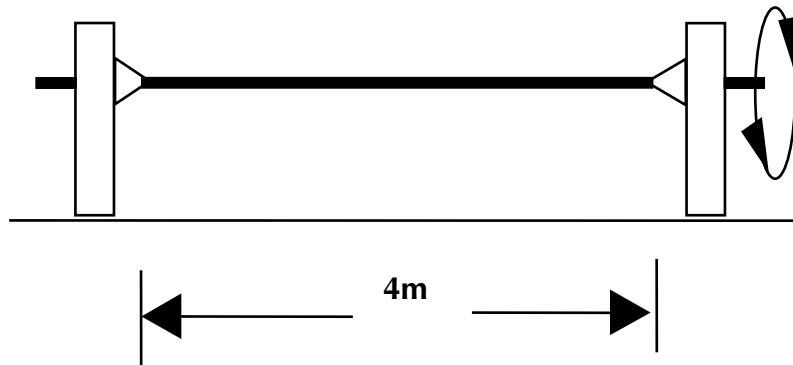

Fig.3-9 Torsion Tester

d. Test conditions and results

Standard No.: IEC 794-1-2-E7/ EIA/TIA-FOTP-455-85

Cable Length for testing: 4 m

Load: 45 N

Frequency used: 1 cycle per minute for 10 cycles

Duration: 5 minutes

Criteria: Attenuation increase less than 0.2 dB

Results:



NEX1 Technologies Co., Ltd

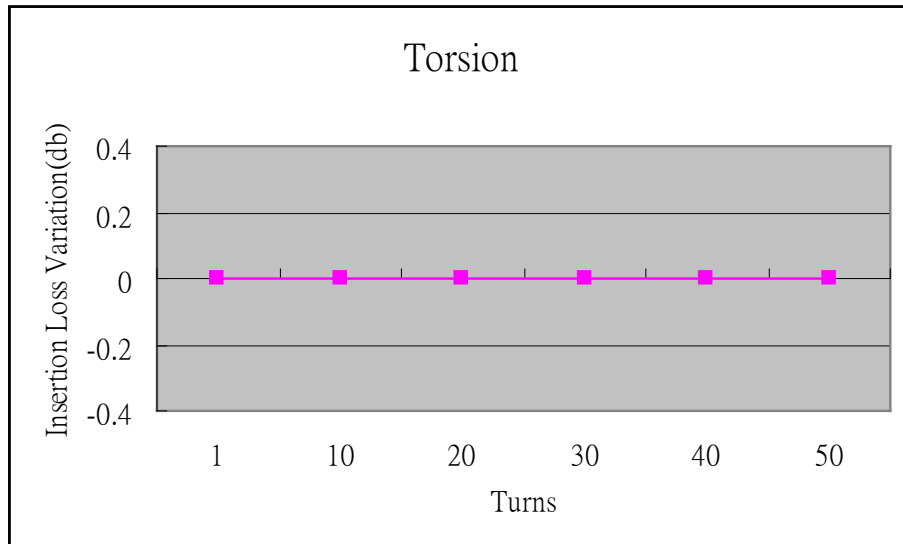

Fig.3-10 The average insertion loss variation of cable torsion test

3-6 BendingTest

a.Purpose

The purpose of this test is to determine the ability of NEX1's mini-armored optical fiber cable to withstand being around a test mandrel. we measure it's loss variation according to the IEC 60794-1-2-E11 and TIA/EIA-455-37



NEX1 Technologies Co., Ltd

b. Apparatus

- (1) Test mandrel
- (2) Optical power and back-reflection meter-JDSU RM3750

c. Testing Method

As IEC-794-1-2-E11/ EIA/TIA-FOTP-455-37, The sample shall be wrapped in a close helix around the mandrel at a uniform rate. Sufficient tension shall be applied to ensure that the sample contours the mandrel. The sample then unwrapped. After that we measure its loss variation, the loss increase is less than 0.2 dB.

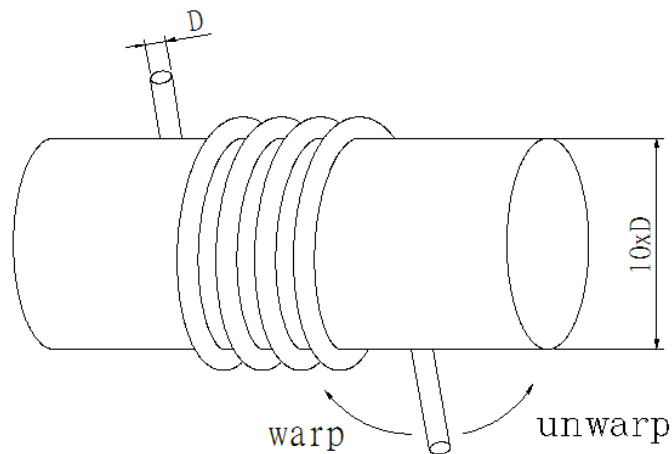

Fig.3-11 Schematic diagram of bending test

d. Test conditions and results

Standard No.: IEC 794-1-2-E11/ EIA/TIA-FOTP-455-37

Diameter of test mandrel for : 30 mm

Number of turns: 4 turns

Frequency used: 1 cycle per minute for 10 cycles

Criteria: Attenuation increase less than 0.2 dB



NEX1 Technologies Co., Ltd

Results:

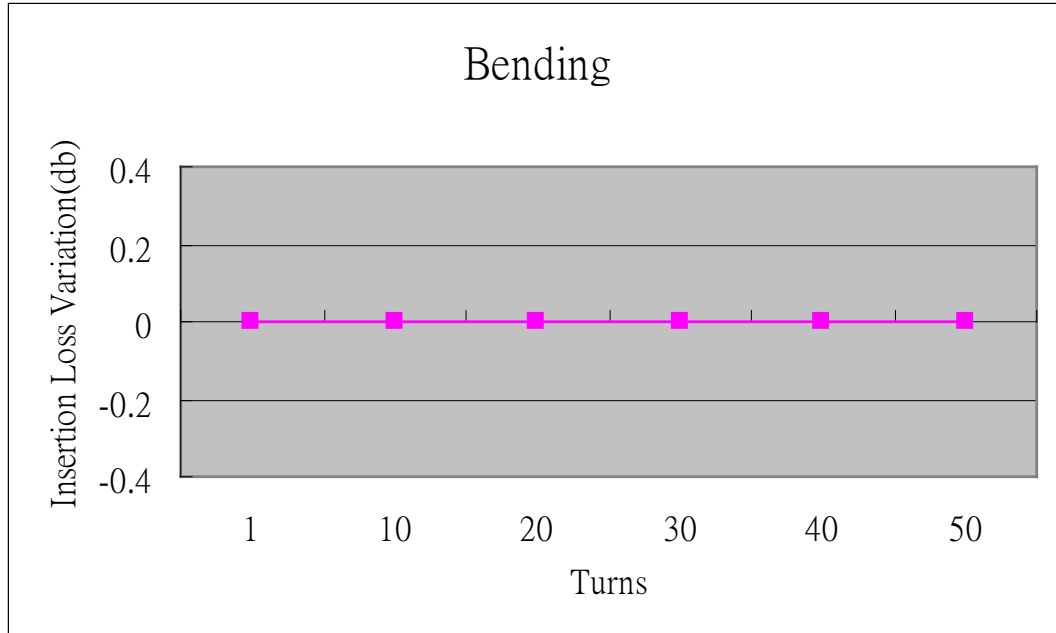

Fig.3-12 The average insertion loss variation of cable bending test



Chapter 4 Conclusion

According to the performance criteria mentioned in section 2-2, all samples passed the test successfully. The result is summarized in Table 4-1.

Table 4-1. Mechanical test results summary for NEX1's mini-armored optical fiber cable.

	Mechanical Test	Number of Samples	Date Completed	Number Passed	Number Failed
1	Tensile Test	5	12/06 2004	5	0
2	Crush	5	12/08 2004	5	0
3	Impact Test	5	12/08 2004	5	0
4	Repeated Bending Test	5	1/13 2005	5	0
5	Torsion	5	1/17 2005	5	0
6	Bend	5	1/17 2005	5	0

Chapter 5 Reference

1. IEC 60794-1-2 "Generic Specification –Basic Requirements Optical Cable Test Procedures " 2nd edition, 2003, IEC.

2. IEC 60794-1-2-E1 Tensile Performance, 2nd edition, 2003, IEC

3. IEC 60794-1-2-E3 Crush, 2nd edition, 2003, IEC



NEX1 Technologies Co., Ltd

4. IEC 60794-1-2-E4 Impact , 2nd
edition,2003,IEC
5. IEC 60794-1-2-E6 Repeated Bending , 2nd
edition,2003,IEC
6. IEC 60794-1-2-E7 Torsion, 2nd
edition,2003,IEC
7. IEC 60794-1-2-E11 Bend, 2nd
edition,2003,IEC
- 8.TIA/EIA-455-33 A "Fiber Optic Cable Tensile Loading and Bending
Test"
2nd edition, 1987, EIA
- 9.TIA/EIA-455-104 "Fiber Optic Cable Cyclic Flexing Test"
1st edition, 1993, EIA
10. TIA/EIA-455-25 " Repeated impact Testing of Fiber Optic Cables
and Cable Assemblies " 1st edition,1989, EIA
11. TIA/EIA-455-41 "Compressive Loading Resistance of Fiber Optic
Cables"
1st edition, 1985, EIA
12. TIA/EIA-455-85 "Fiber Optic Cable Twist Test" 1st edition, 1992,
EIA
13. TIA/EIA-455-37 "Fiber Optic Cable Bend Test Low and High
Temperature " 1st edition, 1993, EIA
- 14 "GR-409-Core" "Generic Requirements for Premises Fiber Optic
cable" Issue1,1994,
Telcordia.